



DACRYL[®]

**PIVOT DOOR
OPENING FIXED FRAME**

technical drawing P-1

PIVOTED DOOR WITH FIXED SASH : DETAILS AND FINISHES

Opening frame

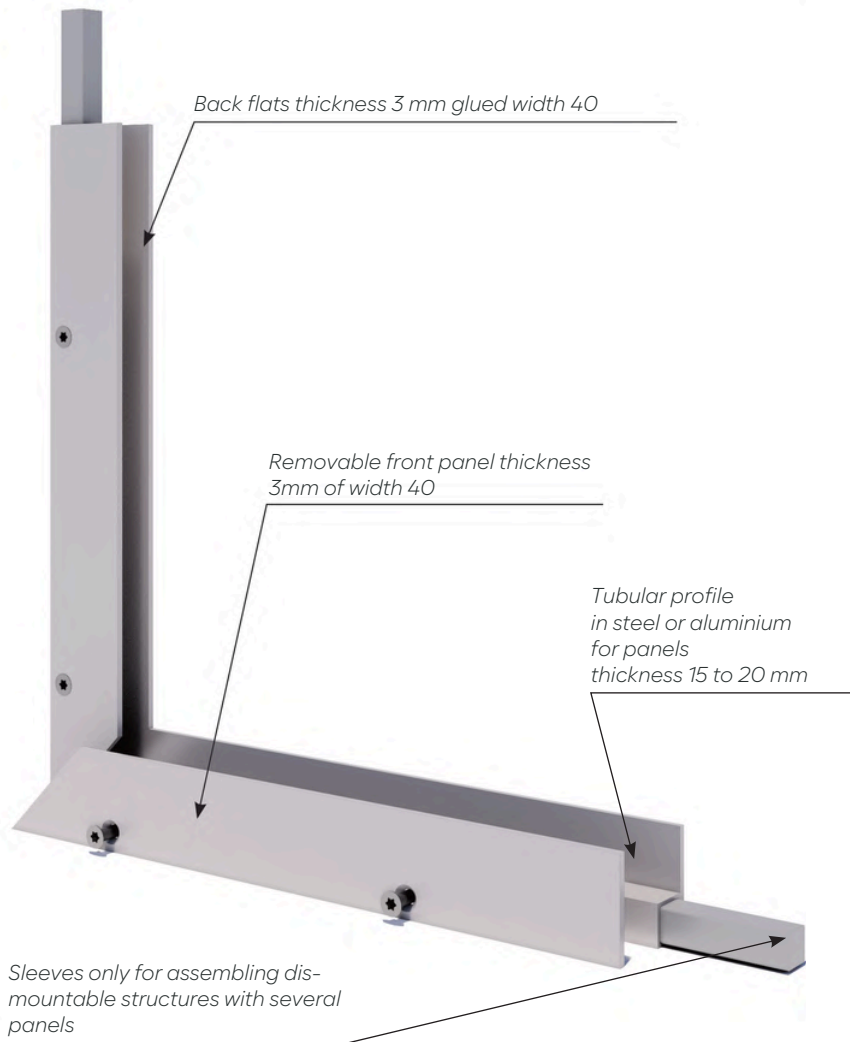

Dimensions

- Square tubular structure in steel

for Dacryl® 15 mm thick:
16 × 16 mm

- Closing dishes
width 40 mm / thickness 3 mm

- Finishing plates
width 20 mm / thickness 2 mm

Frame finishes



Finishing dishes



PIVOT DOOR : OPENING FIXED FRAME

Technical drawing P-1



Pivoted door with frame, finish: mirror-polished stainless steel

Uses

- In impost

Bindings

- Doorframe
- Opening on top and bottom pivot

Option

- LEDlightning
- Offset pivot
- Dacryl® handle

Dimensions

- Standard doors:
W 830 x H 2040

- Door frame:
angle irons 40 x 20
with tubular reinforcement 40 x 20

- Closing dishes
width : 40 mm
thickness 3 mm

- Finishing dishes
width : 40 mm
thickness 2 mm

Deliverables

Delivered ready to install:

- Dacryl® panels in pivot-opening frame
- Door frame ready to be fixed
- Wire outlet welded on installed LED, coming out of the pivot
- Remote 220 V power supply for 12v/24v LED lighting
- Full-height handle on frame opening on 1 side

PIVOT DOOR : OPENING FIXED FRAME

Technical drawing P-1

Description of deliverables

*Adjustable and removable top pivot
for frame-mounted door installation
frame*

*Floor-mounted bottom pivot with ball
bearing and sliding washer*

*Frame with 40 mm wide
flats, 3 mm thick, with
reinforcing tubes and
low pivot to be fixed in
reserve*

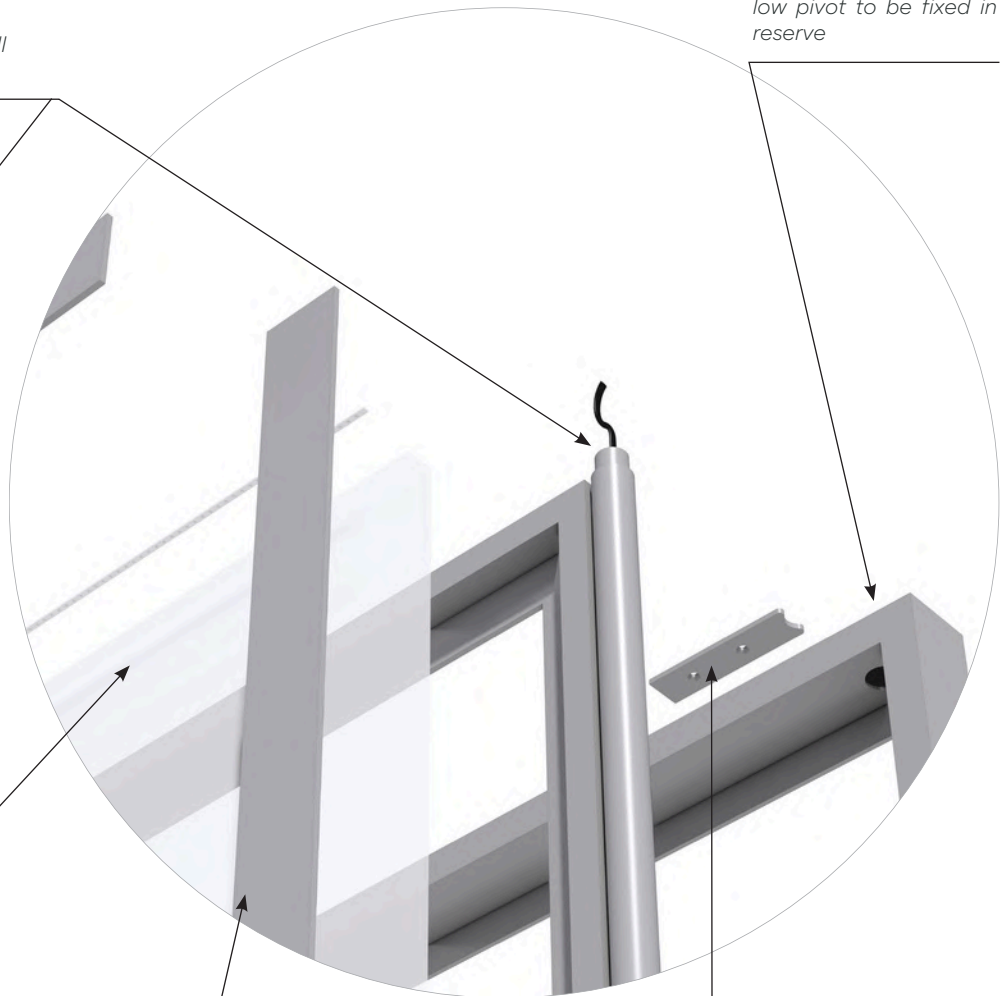

*Dacryl® in opening
tubular frame
with LED lighting and
wire outlet in top pivot*

*Closing plates
straight cuts for gluing*

*Door adjuster and
pivot lock*

PIVOT DOOR : OPENING FIXED FRAME

Technical drawing P-1



PIVOT DOOR : OPENING FIXED FRAME

Technical drawing P-1

General informations

CHASSIS OUVRANT/DORMANT PORTE SUR PIVOT

Etoçpla ainrda gboet tào mp rleédc riisbebrons or periph

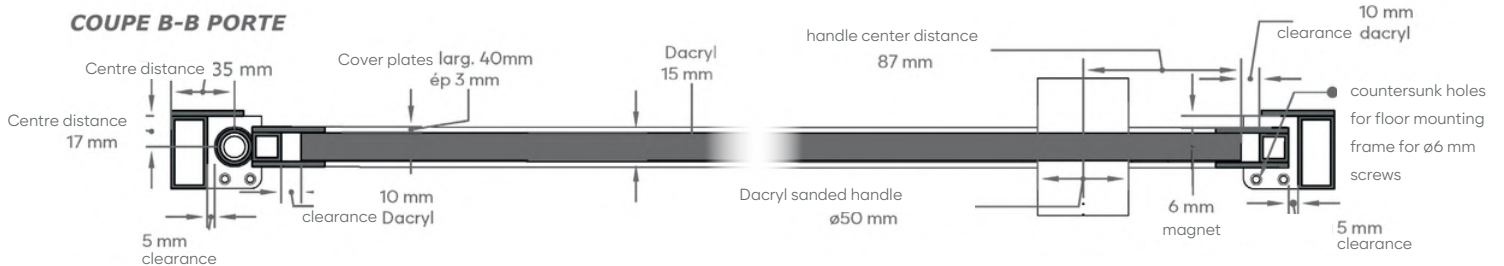
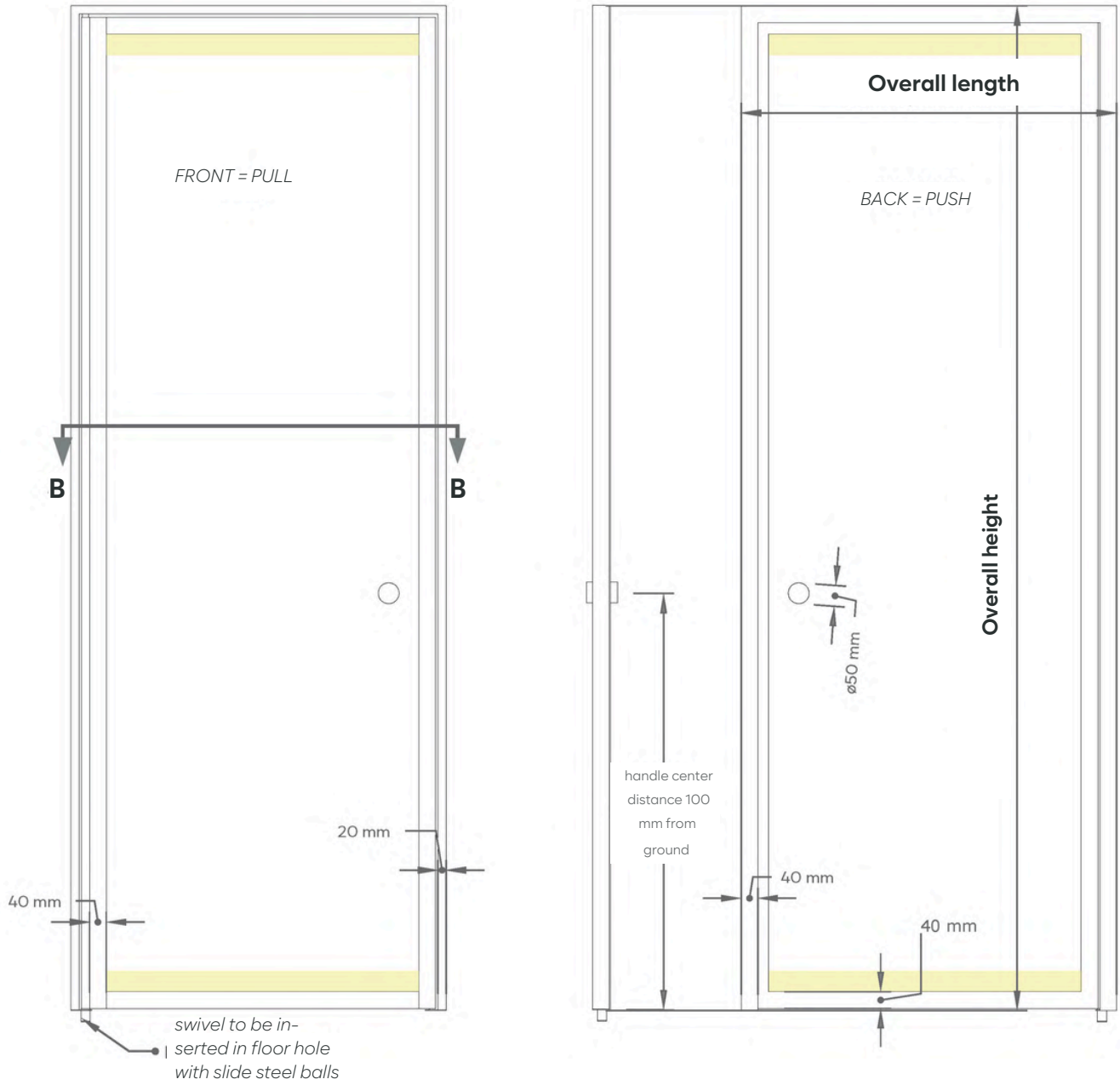

PIVOT DOOR : OPENING FIXED FRAME

Technical drawing P-1

Technical plan product description

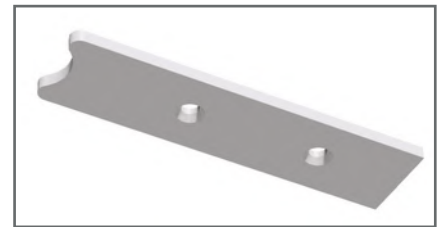
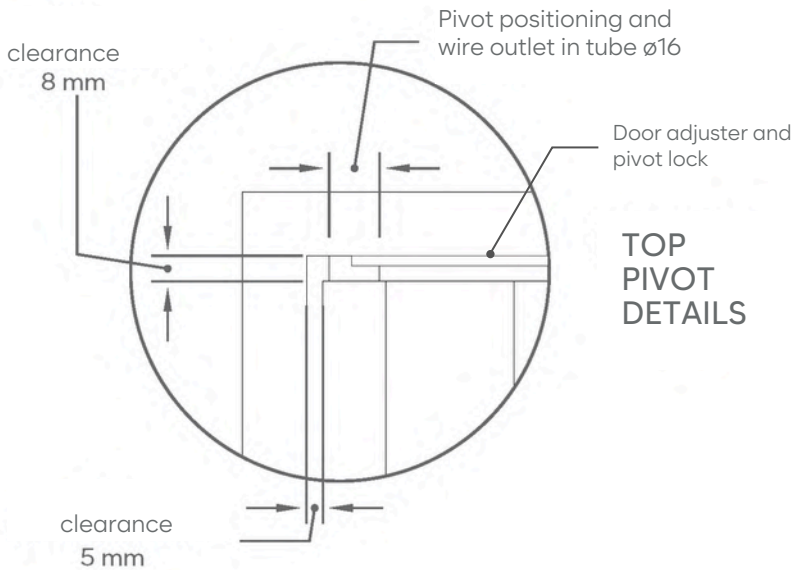
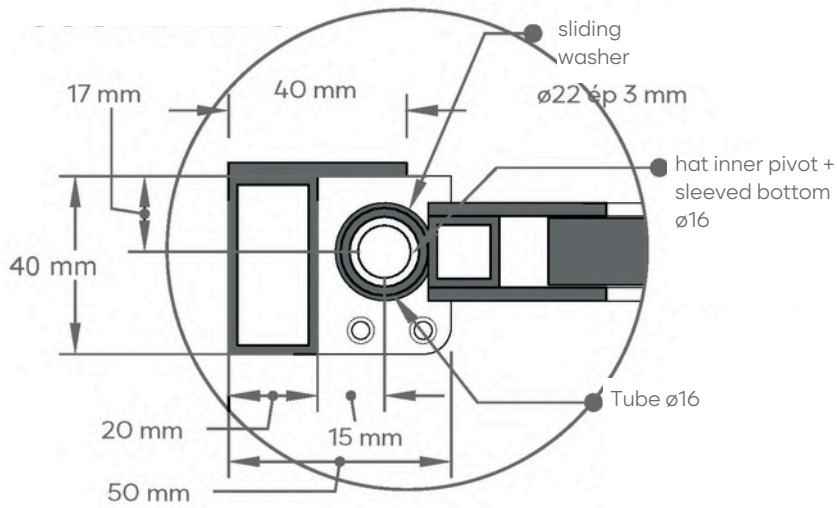

Door adjuster and pivot lock 100 x 20 th. 3 mm

