

DACRYL®



DACRYL® ASSEMBLY ACCESSORIES

DACRYL® MOUNTING WASHER

Technical drawing RD-1

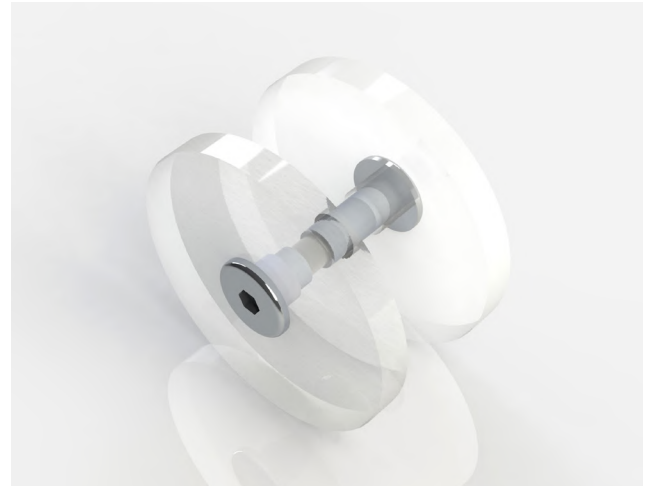

Uses

- Joining piece for joining colourless plates
- Available for Dacryl® th 15 to 20 mm in round cut

Specifics

- Inside faces frosted / outside polished
- Fastening with binding screws

Option

- With inclusions

Dimensions

RD-1 : round \varnothing 55 mm / thickness 5 to 8 mm

General informations

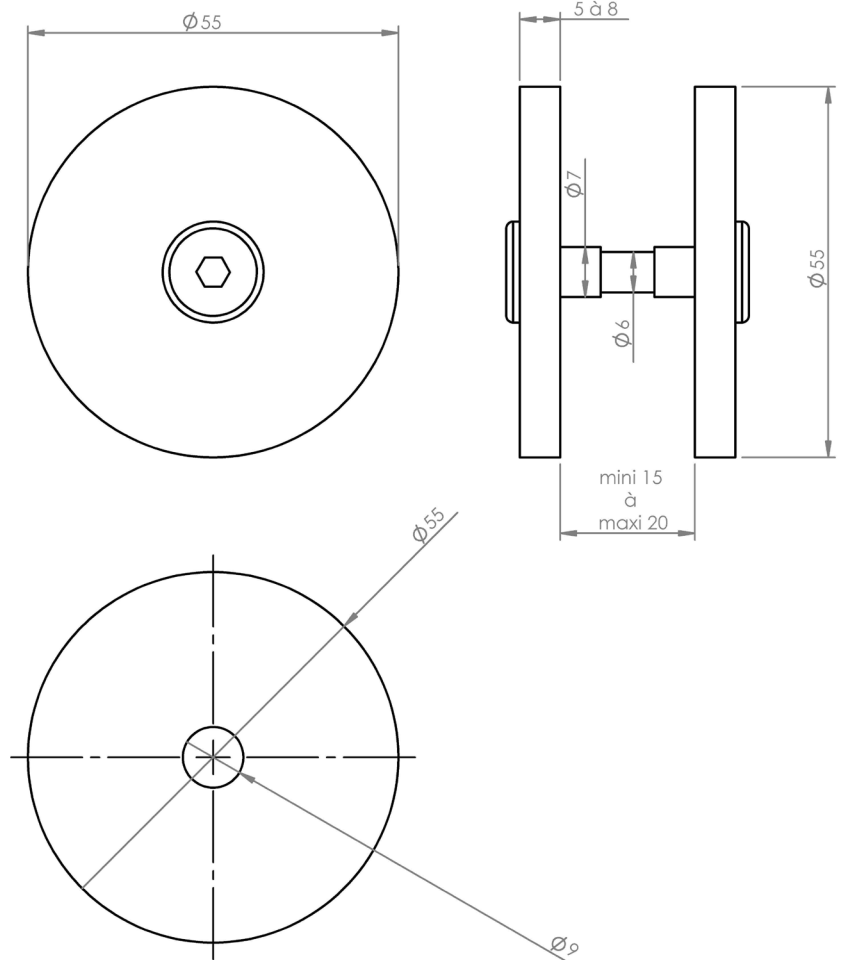
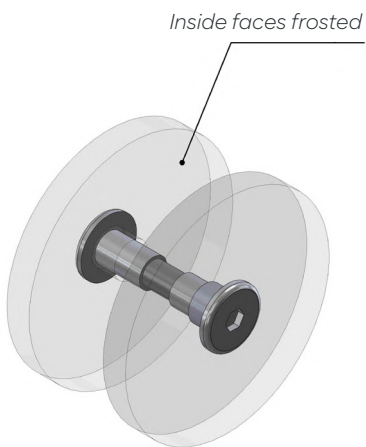

DACRYL® MOUNTING PLATE

Technical drawing PA



Uses

- Mounting piece for colourless straight plates

Specifics

- Fastening with binding screws
- Bending is possible

Option

- With inclusions
- Inside faces frosted / outside polished
- Square version

Dimensions

96.5 x 96.5 x H 55 / Thickness 5 to 8 mm

General informations

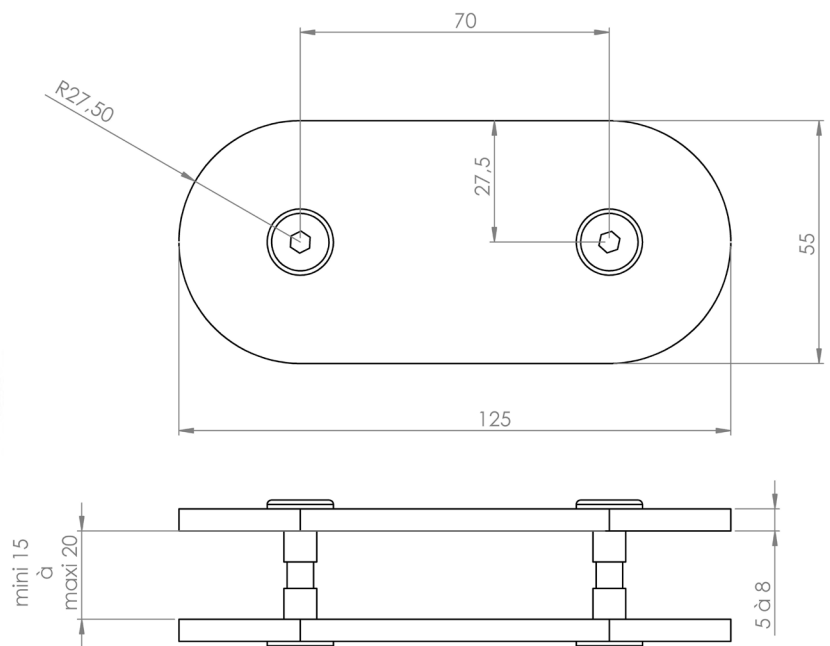
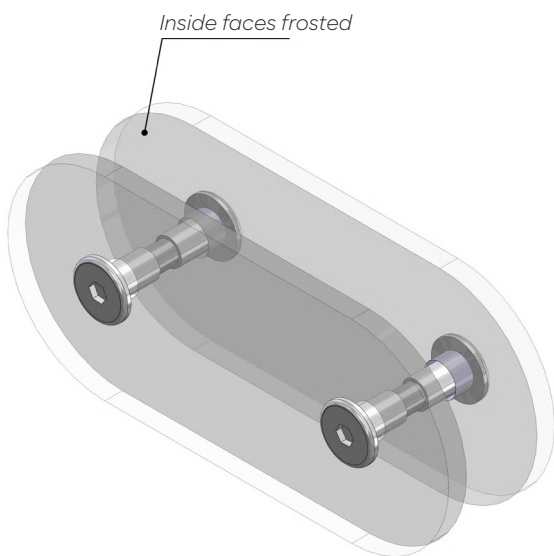

DACRYL® MOUNTING BRACKET

Technical drawing EQ

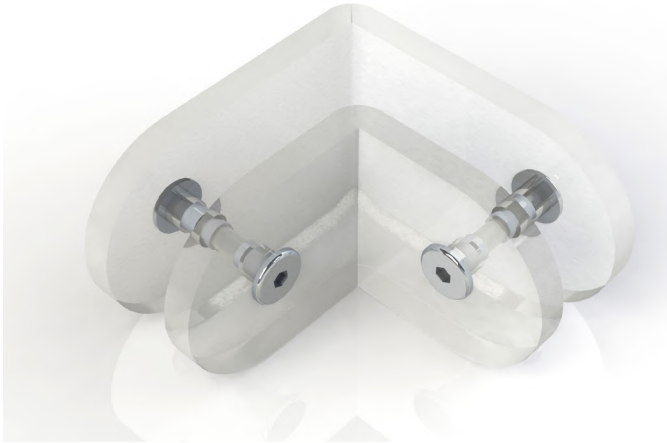

Uses

- Fastening piece for joining plates at corners, colourless
- available for Dacryl® thickness 15 or 20 mm in small and large models

Specifics

- Option frosted inside / polished outside
- Fastening with binding screws

Option

- With inclusions
- Square version

Dimensions

96.5 x 96.5 x H 55 / Thickness 5 to 8 mm

General informations

REF EQ-1A / 20 MM

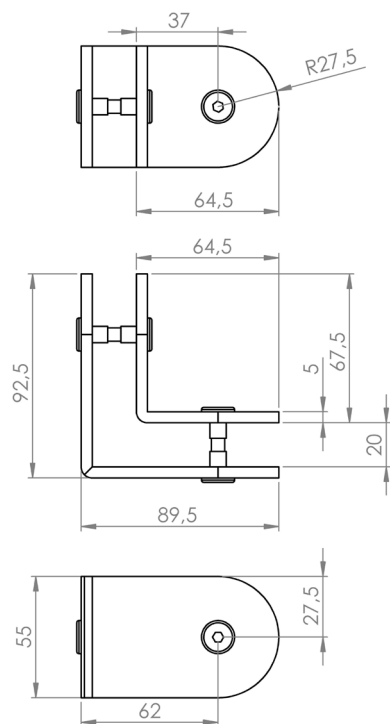

REF EQ-2A / 20 MM

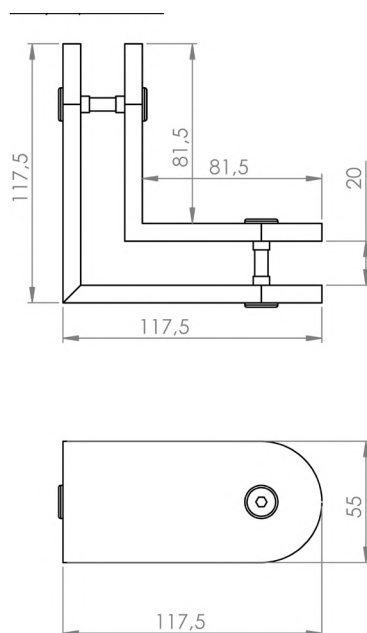

Inside faces frosted

